



3-80E

Carriers

For 3-5ton excavators

Hydraulics

Flow 55 l/m

Pressure 200 bar

Weight

290Kg

Capacity

0.18m³

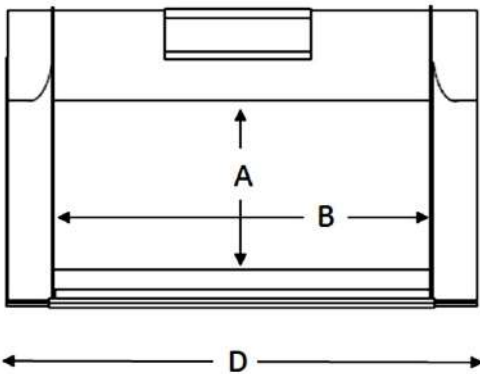

Screening area

430mm x 800mm

Dimensions (mm)

A 430 B 800

C 500 D 1010

E 760 F 640

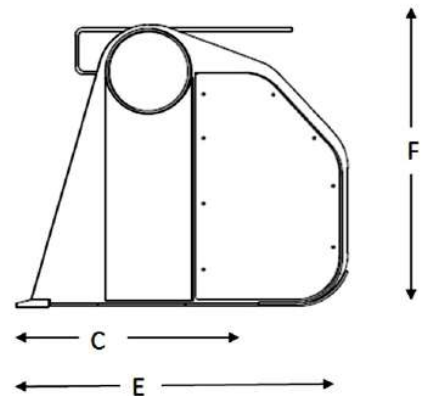

Fast efficient screening systems



True compact screening

Low maintenance bucket

Poly stars which screen without crushing

Large screening area to maximise output